

F-2 ISO-STANDARD CASN

Two way plug valve for fluctuation temperatures, Chemical Sealing System Type CASN/CASN-SL, with ISO-top flange

DIN-EN: DN 15 - 600 / PN 10 - 40

ASME: NPS ½" - 24" / class 150 - 300

PT range: $-30 < T < 230/280^{\circ}\text{C}$, vacuum 10-8 mbar



Design Features

Design Characteristics

- free of cavities
- maintenance free - self lubricating
- mounting-flange for actuators acc. to DIN ISO 5211
- easy accessible adjustment of the plug, even with mounted actuator
- vacuum tight
- fugitive emission resp. clean air act certified (TA-Luft 2002 approval)
- Directive 2014/68/EU
- FDA conformity

PT-Diagram

General Pressure-Temperature-Diagram

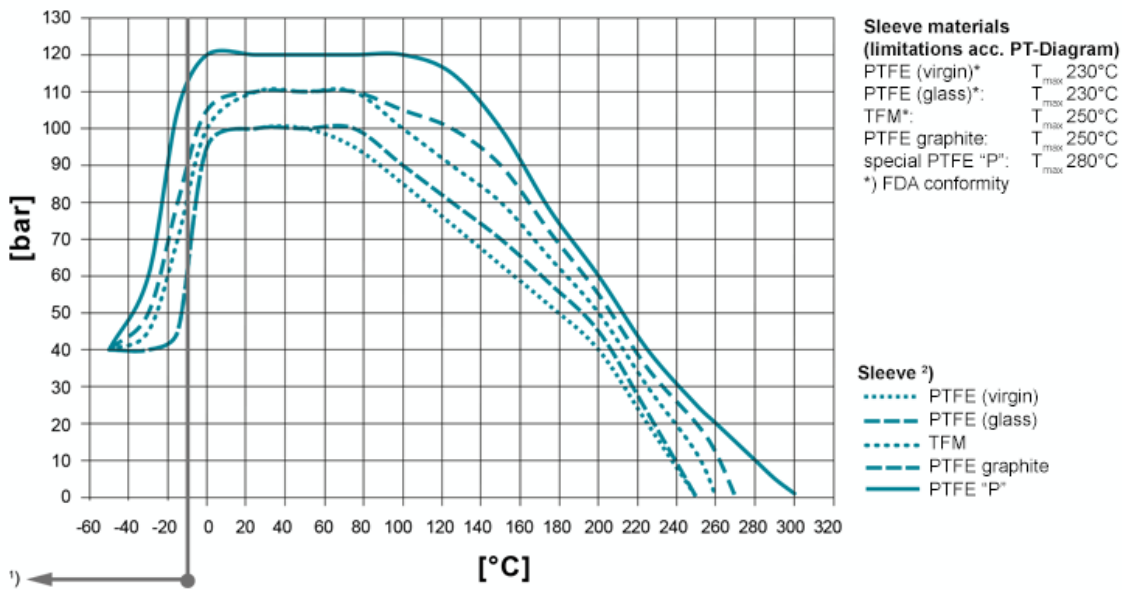

Operating temperatures < -30°C and > 220 °C have to be checked and approved by AZ according to the operating conditions.

Besides the P/T value of the sleeve the limitations of the valve bodies also have to be considered. Please refer to the EN 12516-1 resp. ASME B16.34 in order to choose a proper pressure rating (PN/class). The shown values refer to austenitic stainless steel 1.4408 (A351 Gr. CF8M).

- 1) For operating temperatures below -10°C low temperature / austenitic steels are required.
- 2) Sleeve: There are different sleeve materials / compounds available.

Materials

Standard body materials

- Carbon Steel 1.0619, ASTM A216 WCB
- Stainless Steel 1.4408, ASTM A351 CF8M
- Stainless Steel 1.4308, ASTM A351 CF8
- Unalloyed stainless steel casting (low Temp.) 1.1138, LCC/LCB/A352

Standard plug materials

- Stainless Steel 1.4408, ASTM A351 CF8M
- Stainless Steel 1.4308, ASTM A351 CF8

Special materials

- Ductile cast iron ENJS 1049, ASTM Gr 60-40-18 / A395
- Alloy
- Monel

- Nickel
- Zirconium
- Titan
- Tantal
- other materials on request

Sealing Systems

Chemical safety sealing for fluctuating temperatures with 3x PTFE packing (adjustment) for additional stem sealing;

Tmax 230°C

Type CASN

[read more \[...\]](#)

Chemical safety sealing for fluctuating temperatures with 3x PTFE packing (live loaded disc springs) for additional

stem sealing; Tmax 230°C

Type CASN-SL

[read more \[...\]](#)

Port Forms

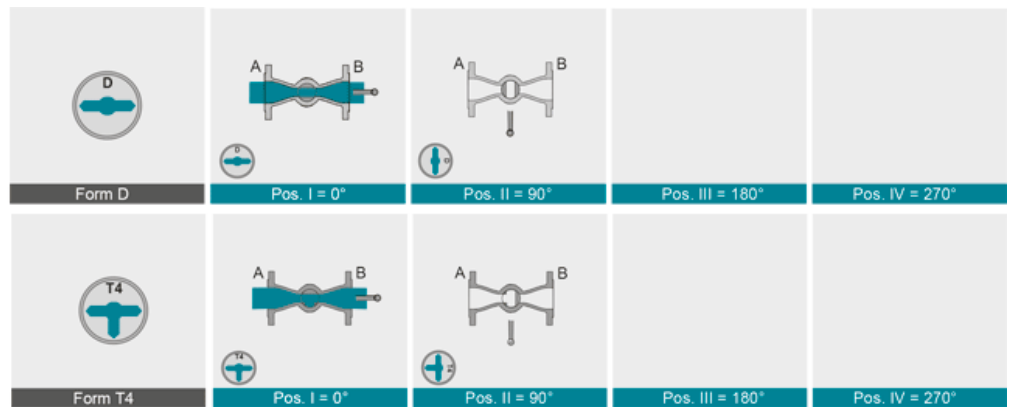
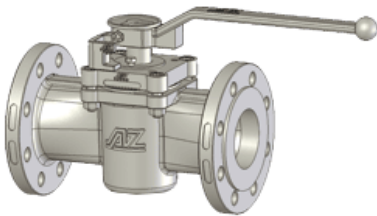

Dimensions

AZ-ISO-bracket
for actuator

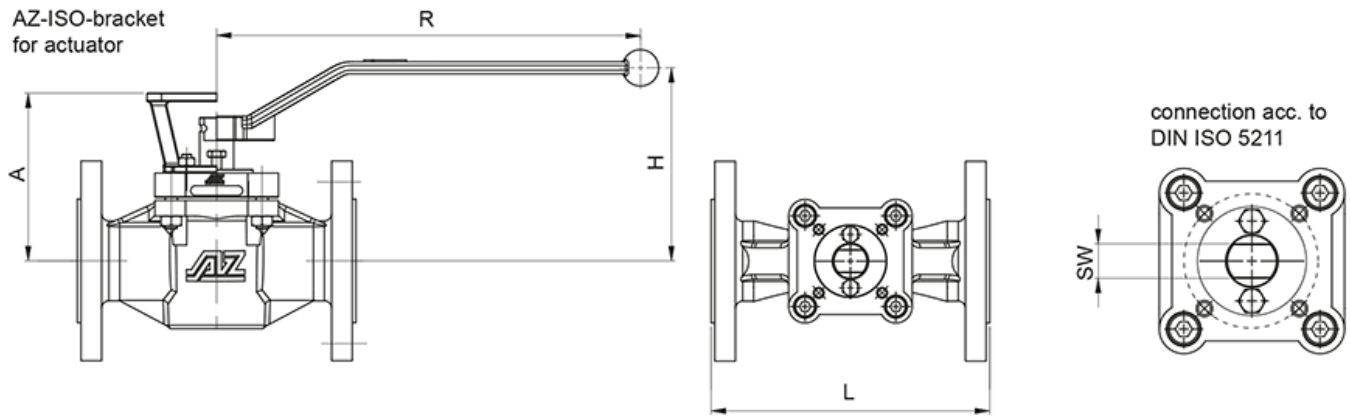

DIN EN 1092-1 / 558-1

ASME B 16.5 / 16.10

DN	PN	L	øD	bracket / lever			DIN flange	dihe-dron	torque* [Nm]	weight [kg]	K _{vs} -value [m³/h]	C _v -value [US.gal/min]
				A	H	R						
15	10-40	130	95	115	130	200	F05	11	30	3,8	12	14
20	10-40	150	105	115	130	200	F05	11	30	4,3	13	15
25	10-40	160	115	120	135	200	F05	11	30	4,9	25	29
32	10-40	180	140	145	170	320	F07	14	70	8,6	46	53
40	10-40	200	150	150	170	320	F07	14	80	9,6	85	98
50	10-40	230	165	180	195	420	F07	19	120	13,9	160	185
65	10-16 25-40	290	185	205	210	600	F10	22	200	19,3	262	302
80	10-40	310	200	205	210	600	F10	22	200	21,4	275	317
80S	10-40	310	200	205	210	600	F12	22	300	24,6	417	482
100	10-16 25-40	350	220 235	205	210	600	F10	22	200	24,6	197	228
100S	10-16 25-40	350	220 235	215	215	600	F12	22	300	28,9	582	673
NPS	class	L	øD	bracket / lever			DIN flange	dihe-dron	torque* [Nm]	weight [kg]	K _{vs} -value [m³/h]	C _v -value [US.gal/min]
				A	H	R						
½"	150	108	90	88	103	200	F05	11	30	2,7	14	16
	300	140	95							3,8	13	15
¾"	150	117	100	88	103	200	F05	11	30	3,2	13	16
	300	152	115							4,3	13	15
1"	150	127	110	94	109	200	F05	11	30	3,5	24	28
	300	165	125							4,9	26	31
1¼"	150	140	115	102	117	320	F07	14	70	5,4	46	53
	300	178	135							8,6		
1½"	150	165	125	109	124	320	F07	14	80	7	78	90
	300	190	155							9,6	79	92
2"	150	178	150	139	159	420	F07	19	120	11,8	145	167
	300	216	165							13,9	156	180
2½"	150	190	180	158	165	600	F10	22	200	15,5	236	273
	300	241	190							19,3		
3"	150	203	190	158	165	600	F10	22	200	18,2	225	260
	300	282	210							21,4	228	264
4"	150	229	230	158	165	600	F10	22	200	20,3	169	195
	300	305	255							24,6	198	229
4"S	150	229	230	173	180	600	F12	22	300	24,6	523	604
	300	305	255							28,9	542	627

* inclusive 100% safety factor for actuators

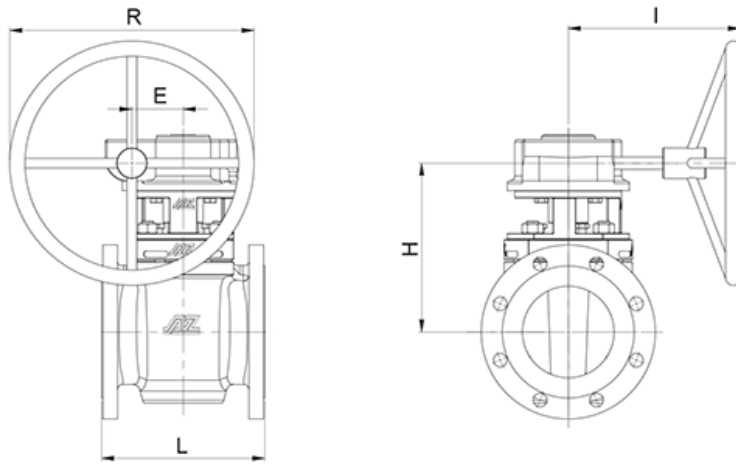

DIN EN 1092-1 / 588-1

ASME B 16.5 / 16.10

DN	PN	L	E	gear (Pro-Gear)			Type	DIN flange	SW	torque. [Nm]*	weight [kg]**	K _{v5} -value [m ³ /h]**	C _v -value [US.gal/min]**
				R	H	I							
125	10-16	325	84	400	277	290	Q1500-S	F16	36	900	67	865	1000
	25-40										71		
150	10-16	350	84	400	277	290	Q1500-S	F16	36	900	77	875	1011
	25-40										79		
200	10-16	400	117,5	500	325	365	Q3000-S	F16	36	1200	108	1770	2047
	25 40										119		
250	10 16	450	117,5	600	328	465	Q5000-S	F16	36	1500	177	2788	3223
	25 40										235		
300	10 16	500	117,5	600	366	465	Q5000-S	F16	36	2600	230	2618	3027
	25 40										249		
350	10 16	550	137,5	600	460	465	Q6500-S	F25	46	5500	395	5070	5861
	25 40										468		
400	10 16	600	137,5	600	460	465	Q6500-S	F25	46	5500	411	4694	5426
	25 40										525		
450	10 16	650	180	600	485	520	Q12000-S	F30	55	6400	611	9587	11084
	25 40										730		
500	10 16	700	180	600	510	520	Q12000-S	F30	55	7500	655	10260	11862
	25 40										744		
600	10 16	800	180	600	510	520	Q12000-S	F30	55	7500	681	7980	9226
	25 40										863		
NPS		L	E	gear (Pro-Gear)			Type	DIN flange	SW	torque. [Nm]*	weight [kg]**	K _{v5} -value [m ³ /h]**	C _v -value [US.gal/min]**
				R	H	I							
5"	150	254	84	400	277	290	Q1500-S	F16	27	900	55		
	300	325									71		
6"	150	267	84	400	277	290	Q1500-S	F16	27	900	60	738	853
	300	403									70	775	896
8"	150	292	117,5	500	325	365	Q3000-S	F16	36	1200	94	1517	1754
	300	419									125	1978	2286
10"	150	330	117,5	600	328	465	Q5000-S	F16	36	1500	127	2239	2589
	300	457									160	2382	2754
12"	150	356	117,5	600	366	465	Q5000-S	F16	36	2600	153	1904	2202
	300	502									170	1925	2225
14"	150	686	137,5	600	460	465	Q6500-S	F25	46	5500	180	2448	2830
	300	762									210	2394	2768
16"	150	600	137,5	600	460	465	Q6500-S	F25	46	5500	246	5131	5932
	300	600									305	4618	5339
18"	150	864	180	600	485	520	Q12000-S	F30	55	6400	627	12427	14367
	300	914									763		
20"	150	914	180	600	510	520	Q12000-S	F30	55	7500	698	11728	13559
	300	991									860	11841	13689
24"	150	1067	180	600	510	520	Q12000-S	F30	55	7500	825	9863	11402
	300	1143									1070	9509	10993

* inclusive 100% safety factor for actuators

For geometric reasons, threads are used in the flange bores in a few cases

Actuation

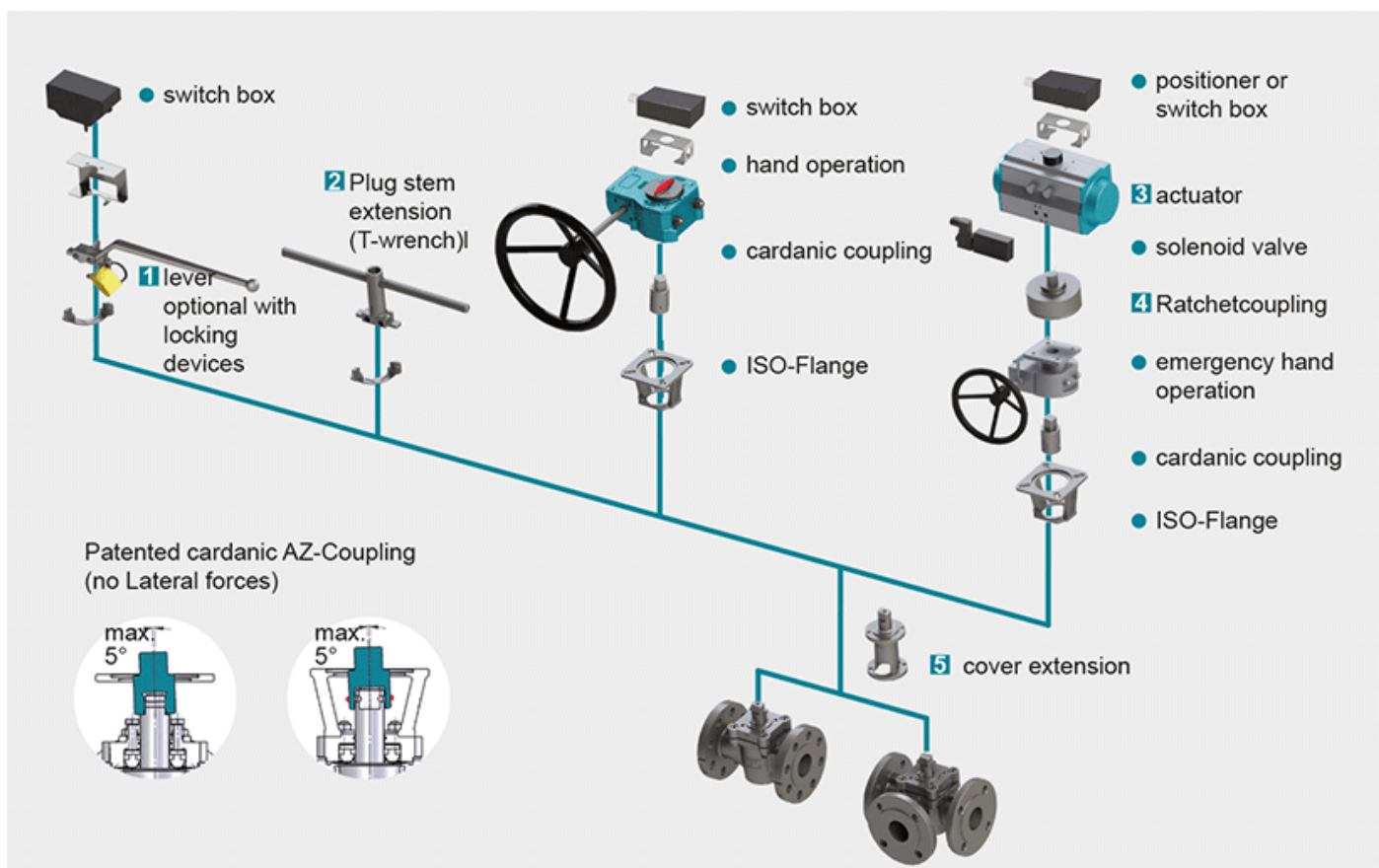

1 Locking Devices

Pilot valve combinations, pad lock eyelets, linear key conception, indexing plunger arrestor.
read more [...]

2 Plug stem extension

Solid construction in stainless steel with T-wrench, Standard extension 100 mm or 150 mm, non standard lengths are available on request
read more [...]

3 Actuators

Actuators for mounting-flange acc. to DIN ISO 5211
read more [...]

NEW: Pneumatic actuator AIR GEAR for plug valves with high torque =150.000 Nm
read more [...]

4 Ratched coupling

To usw on multiport valves with standard 90° actuator for bigger switchpositions than 90°
read more [...]

5 Cover extension

Solid construction in stainless steel, Standard extension 100 mm or 150 mm high, non standard lengths are available on request . Hexagonal bolts on adjustment ring freely accessible. Note: Don't use with sealing

FSN/FSN-SL and CASN/CASN-SL
[read more \[...\]](#)